

CANTONI
MOTOR



***Three-Phase
Motors with
Increased
Rated
Output***



ISO 9001



Product Catalogue

Three-Phase Motors with Increased Rated Output

The catalogue covers industrial squirrel cage motors for general purpose.

The outputs of these motors - for appropriate frame sizes are higher than defined in European Standard EN 50347 although the mounting dimensions remain unchanged.

Our motors are designed for long life and reliable operation in severe industrial applications.

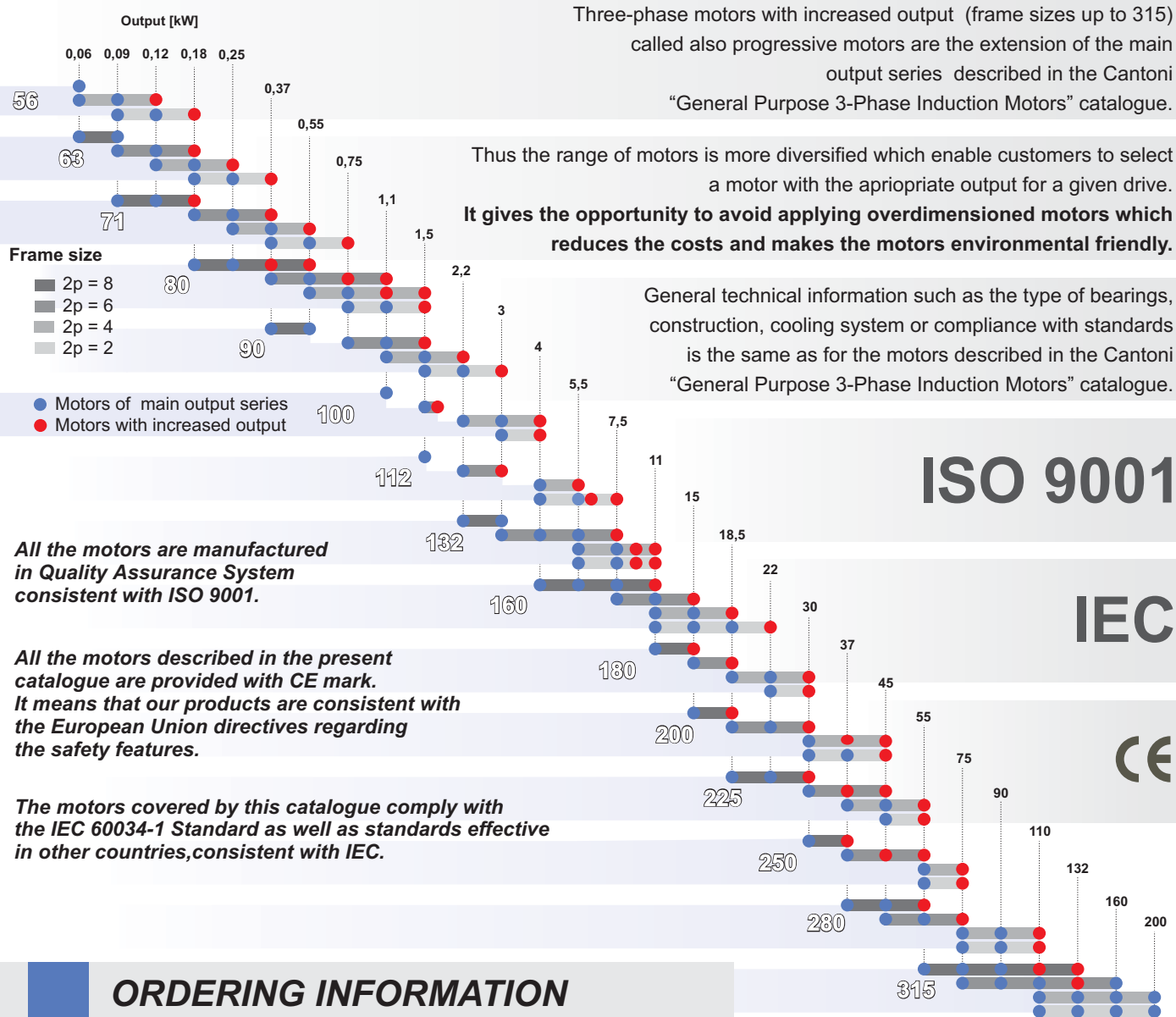

All the motors are manufactured in Quality Assurance System consistent with ISO 9001.

All the motors described in the present catalogue are provided with CE mark. It means that our products are consistent with the European Union directives regarding the safety features.

The motors covered by this catalogue comply with the IEC 60034-1 Standard as well as standards effective in other countries, consistent with IEC.

As part of our development programme, we reserve the right to alter or amend any of the specifications included in this catalogue without giving prior notice.

Totally Enclosed Motors IP55
Insulation Class F

Item	Type	Rated Output		Rated Speed	Rated Torque	Efficiency	Power Factor	Full Load Current		Locked Rotor Torque	Locked Rotor Current	Breakdown Torque	Moment of Inertia	Weight (IMB3)
		P_N						η_N	T_N					
		[kW]	[HP]	[rpm]	[Nm]	[%]	[-]	[A] _{230V}	[A] _{400V}	T_L/T_N	I_L/I_N	T_b/T_N	J	m
2p=2 $n_s=3000$ rpm														
1.	STg 56X-2C	0,18	0,25	2820	0,61	70	0,64	1,1	0,6	2,7	4	3	0,0001	3,7
2.	STg 63X-2C	0,37	0,5	2780	1,27	65	0,82	1,9	1,1	2,5	4,5	2,5	0,00031	5,1
3.	Sh 71X-2C	0,75	1	2780	2,58	75	0,85	3,1	1,8	2,1	4,8	2,2	0,000691	7,6
4.	Sh 80X-2C	1,5	2	2800	5,09	77	0,84	5,9	3,4	3	5	2,8	0,001422	11,6
5.	Sh 80X-2D	2,2	3	2820	7,41	81	0,75	9	5,2	3,2	5,3	3	0,001673	13,2
6.	PSg 90L-2	3	4	2845	10,1	81,1	0,82	11,4	6,6	3,2	6,6	3,6	0,0017	18,9
7.	PSg 100L-2	4	5,5	2885	13,2	82,7	0,85	14,2	8,2	1,9	5,8	2,7	0,0048	25
8.	PSg 112M-2	5,5	7,5	2890	18,2	86	0,86	-	10,7	2,5	7,1	3,2	0,006	34
9.	PSg 112M-2A	6	8,1	2890	19,8	86,7	0,83	-	12	2,9	7,6	3,35	0,0067	36,5
10.	PSg 112M-2B	7,5	10	2880	24,9	86,8	0,87	-	14,3	2,5	7	3	0,0074	39
11.	PSg 132M-2	9,2	12,4	2920	30,1	88,5	0,89	-	16,8	2,7	7,8	3,2	0,019	75
12.	PSg 132S-2	11	15	2920	36	88,2	0,89	-	20,3	2,9	8,4	3,45	0,017	77,5
13.	PSg 132M-2A	11	15	2920	36	88,2	0,89	-	20,3	2,9	8,4	3,45	0,017	78
14.	Sg 160L2z	22	30	2910	72	90,3	0,91	-	39	2,4	6,5	2,8	0,06	140
15.	PSg 180L-2	30	40	2940	97	90,1	0,89	-	54	2,7	6,5	2,6	0,095	190
16.	Sg 200L2Bz	45	60	2955	145	93,3	0,87	-	79	2	6,3	2,7	0,18	265
17.	Sg 225M2z	55	75	2964	177	94,6	0,89	-	99	2,2	7,3	3	0,26	350
18.	Sg 250M2z	75	100	2970	241	93,5	0,89	-	130	2	6,9	2,5	0,42	480
19.	Sg 280M2z	110	150	2973	353	94,2	0,88	-	192	2	7,6	3	0,87	620
2p=4 $n_s=1500$ rpm														
20.	STg 56X-4C	0,12	0,17	1400	0,82	59	0,62	0,86	0,5	2,2	3	2,2	0,0003	4
21.	STg 63X-4C	0,25	0,33	1400	1,7	69	0,6	1,65	0,95	2,6	3,6	2,7	0,00038	5,1
22.	Sh 71X-4C	0,55	0,75	1400	3,75	70	0,62	3,5	2	2,5	3	2,4	0,001099	7,4
23.	Sh 80X-4C	1,1	1,5	1380	7,61	75	0,76	5	2,9	1,7	4	2	0,002655	11
24.	Sh 80X-4D	1,5	2	1380	10,38	71	0,72	7,5	4,3	2,4	3,8	2,2	0,003123	13,3
25.	PSg 90L-4	2,2	3	1410	14,9	78	0,78	9	5,2	2,65	5,45	2,85	0,0034	19,4
26.	PSg 100L-4	4	5,5	1425	26,8	80,8	0,8	15,4	8,9	2,85	6,6	3,2	0,0067	28,9
27.	PSg 112M-4A	5,5	7,5	1425	36,9	83,9	0,84	-	11,3	2,5	6,45	3,1	0,012	39
28.	PSg 132M-4	9,2	12,4	1450	61	88	0,84	-	18	2,6	8	3,2	0,043	84
29.	PSg 132M-4A	11	15	1450	72	87	0,83	-	22	2,5	7,05	3,15	0,042	82
30.	Sg 160L4z	18,5	25	1450	122	89,8	0,86	-	34,5	2,5	7,5	2,9	0,08	140
31.	PSg 180L-4	30	40	1465	196	91,4	0,9	-	53	2,8	7,5	2,7	0,185	200
32.	Sg 200L4Az	37	50	1466	241	92,2	0,86	-	67	2,1	5,5	2	0,31	270
33.	Sg 200L4Bz	45	60	1463	294	92,1	0,86	-	83	2,1	5,5	1,9	0,37	280
34.	Sg 225M4z	55	75	1476	356	93,6	0,88	-	96	2,5	6,2	2,4	0,55	372
35.	Sg 250M4z	75	100	1475	486	93,5	0,92	-	125	2,7	6,9	2,2	0,93	475
36.	Sg 280M4z	110	150	1480	710	94,2	0,92	-	185	2,3	6,9	2,2	1,67	650

TECHNICAL DATA

Totally Enclosed Motors IP55
Insulation Class F

TECHNICAL DATA

Item	Type	Rated Output		Rated Speed	Rated Torque	Efficiency	Power Factor	Full Load Current		Locked Rotor Torque	Locked Rotor Current	Breakdown Torque	Moment of Inertia	Weight (IMB3)
		P_N						η_N	T_N					
		[kW]	[HP]	[rpm]	[Nm]	[%]	[-]	[A] _{230V}	[A] _{400V}	[-]	[-]	[-]	[kgm ²]	[kg]
2p=6 $n_s=1000$ rpm														
37.	STg 63X-6C	0,15	0,2	870	1,64	48	0,56	1,6	0,9	1,6	2	1,6	0,000422	5,1
38.	Sh 71X-6C	0,37	0,5	880	4,02	60	0,7	2,35	1,35	1,9	2,6	1,8	0,001221	7,3
39.	Sh 80X-6C	0,75	1	900	8	70	0,72	4	2,3	2,1	3,4	2	0,002933	10,8
40.	Sh 80X-6D	1,1	1,5	850	12,4	58	0,75	6,4	3,7	1,6	2	1,5	0,003451	12,5
41.	PSH 90L-6	1,5	2	890	16,1	70,1	0,73	7,3	4,2	2,05	3,65	2,1	0,0031	15,9
42.	PSg 100L-6	1,8	2,4	925	18,6	71,7	0,8	7,8	4,5	1,65	3,9	2	0,009	21,4
43.	PSg 112M-6	3	4	935	30,6	79,4	0,81	-	6,7	1,7	4,35	2	0,0177	33
44.	PSg 132M-6	7,5	10	950	75	84,2	0,79	-	16,2	2,55	6,1	2,9	0,039	78
45.	Sg 160L6z	15	20	955	150	86	0,86	-	29,5	2,2	6,7	2,8	0,1	140
46.	Sg 180L6z	18,5	25	965	183	87,7	0,85	-	36	2,3	5,1	2,2	0,19	157
47.	Sg 200L6z	30	40	979	293	90	0,89	-	54	2,5	6,4	2,6	0,58	330
48.	Sg 225M6Az	37	50	980	361	91	0,87	-	67	2,1	6,3	2,2	0,87	380
49.	Sg 225M6Bz	45	60	978	439	91,4	0,88	-	81	2,2	6	2,0	0,9	400
50.	Sg 250M6Az	45	60	984	437	91,5	0,89	-	79	2,6	6,7	2,0	1,39	480
51.	Sg 250M6Bz	55	75	985	533	92,3	0,87	-	99	2,7	6,7	2,6	1,5	468
52.	Sg 280M6z	75	100	985	727	93,5	0,89	-	131	2,3	6,6	2,1	2,16	670
53.	Sg 315M6Bz	132	180	985	1280	95	0,84	-	238	2,3	5,8	1,6	3,01	895
2p=8 $n_s=750$ rpm														
54.	Sh 71X-8C	0,18	0,25	680	2,52	45	0,52	2,4	1,4	2,7	2	2,6	0,001221	7,3
55.	Sh 80X-8C	0,37	0,5	680	5,2	58	0,6	2,95	1,7	2	2,5	2	0,002933	11
56.	Sh 80X-8D	0,55	0,75	690	7,61	59	0,6	4,2	2,4	2,1	2,5	2,2	0,003451	12,7
57.	Sg 160L8z	11	15	700	150	81,5	0,82	-	23,7	2,7	5,7	2,5	0,1	130
58.	Sg 180L8z	15	20	727	197	88	0,78	-	35	1,8	5,4	2,6	0,19	155
59.	Sg 200L8z	18,5	25	731	242	88	0,81	-	37	1,9	4,7	2	0,47	320
60.	Sg 225M8z	30	40	737	389	90	0,79	-	61	2,3	5,6	2,3	0,87	380
61.	Sg 250M8z	37	50	735	481	90,9	0,83	-	70	2,3	5,3	1,7	1,39	440
62.	Sg 280M8z	55	75	735	715	92,8	0,82	-	104	2,1	5	1,8	2,16	700
63.	Sg 315M8Bz	110	150	737	1425	93,5	0,75	-	226	1,7	4,2	1,7	3,01	850

FOOT MOUNTED MOTORS - IM B3

56 ÷ 180

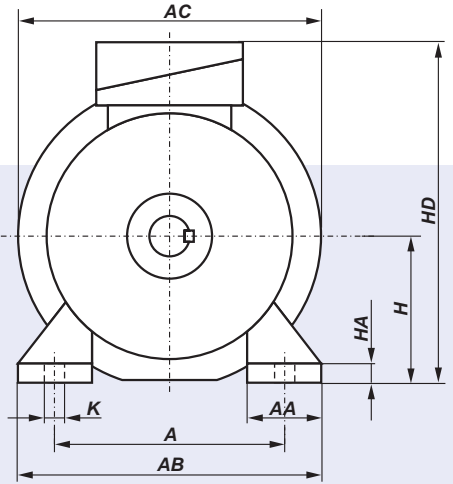
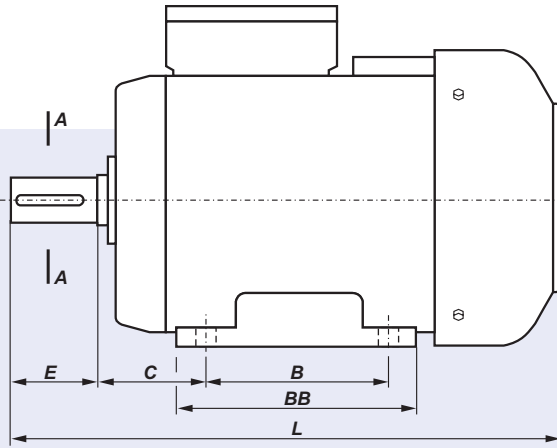
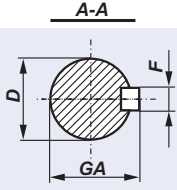

200 ÷ 315

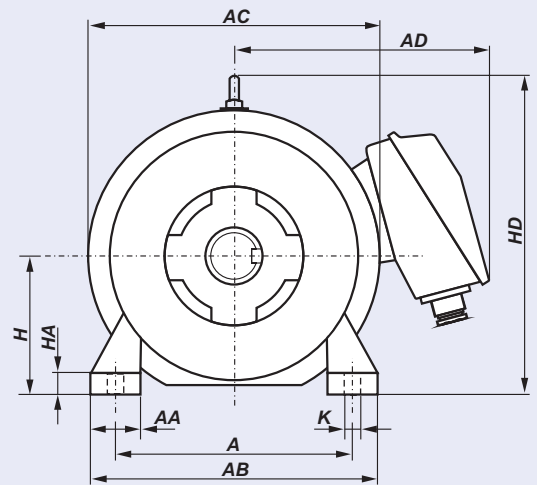
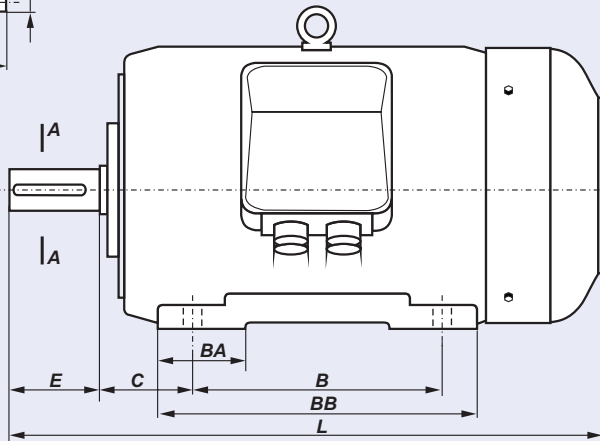
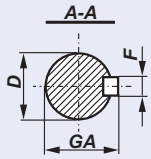

DIMENSION DRAWINGS

Type of motor	A	B	C	D	E	F	GA	H	HA	K	AA	AB	AC	AD	BA	BB	HD	L
STg 56X-2+4C	90	71	36	9j6	20	3h9	10,2	56	7	5,8	30	110	117	-	-	92	154	204
STg 63X-2+6C	100	80	40	11j6	23	4h9	12,5	63	8,5	7	36	124	126	-	-	106	165	228
Sh 71X-2+8C	112	90	40	14j6	30	5h9	16	71	8	7	45	142	141	-	-	116	182	263
Sh 80X-2+8C	125	100	50	19j6	40	6h9	21,5	80	9	10	55	160	150	-	-	130	200	306
Sh 80X-2+8D	125	100	50	19j6	40	6h9	21,5	80	9	10	55	160	150	-	-	130	200	318
PSh 90L-2+4	140	125	56	24j6	50	8h9	27	90	10	10	50	170	185	-	-	153	220	354
PSh 90L-6	140	125	56	24j6	50	8h9	27	90	10	10	50	170	185	-	-	153	220	330
PSg 100L-2+6	160	140	63	28j6	60	8h9	31	100	14	12	45	200	206	-	-	172	240	376
PSg 100L-4	160	140	63	28j6	60	8h9	31	100	14	12	45	200	206	-	-	172	240	411
PSg 112M-2+6	190	140	70	28j6	60	8h9	31	112	14	12	54	230	245	-	-	174	276	384
PSg 112M-2A,2B,4A	190	140	70	28j6	60	8h9	31	112	14	12	54	230	245	-	-	174	276	411
PSg 132S-2	216	140	89	38k6	80	10h9	41	132	16	12	56	278	274	-	-	182	310	531
PSg 132M-2+6,2A,4A	216	178	89	38k6	80	10h9	41	132	16	12	56	278	274	-	-	220	310	531
Sg 160L2+8z	254	254	108	42k6	110	12h9	45	160	20	15	60	300	327	125	-	292	366	649
PSg 180L-2+4	279	279	121	48k6	110	14h9	51,5	180	26	15	70	350	360	-	-	320	408	756
Sg 180M2z	279	241	121	48m6	110	14h9	51,5	180	24	15	75	330	365	125	-	320	400	675
Sg 180L4+8z	279	279	121	48m6	110	14h9	51,5	180	24	15	75	330	365	125	-	320	400	675
Sg 200L2+8z	318	305	133	55m6	110	16h9	59	200	32	19	80	400	450	355	100	380	485	810
Sg 225M2z	356	311	149	55m6	110	16h9	59	225	34	19	85	445	505	375	110	380	535	855
Sg 225M4+8z	356	311	149	60m6	140	18h9	64	225	34	19	85	445	505	375	110	380	535	885
Sg 250M2z	406	349	168	60m6	140	18h9	64	250	36	24	90	495	540	415	120	420	590	980
Sg 250M4+8z	406	349	168	65m6	140	18h9	69	250	36	24	90	495	540	415	120	420	590	980
Sg 280M2z	457	419	190	65m6	140	18h9	69	280	40	24	100	560	620	450	165	520	660	1040
Sg 280M4+8z	457	419	190	75m6	140	20h9	79,5	280	40	24	100	560	620	450	165	520	660	1040
Sg 315M6+8Bz	508	457	216	80m6	170	22h9	85	315	46	28	105	610	620	450	190	560	695	1210

FOOT/FLANGE MOUNTED MOTORS - IM B35
FLANGE MOUNTED MOTORS - IM B5

56 ÷ 180

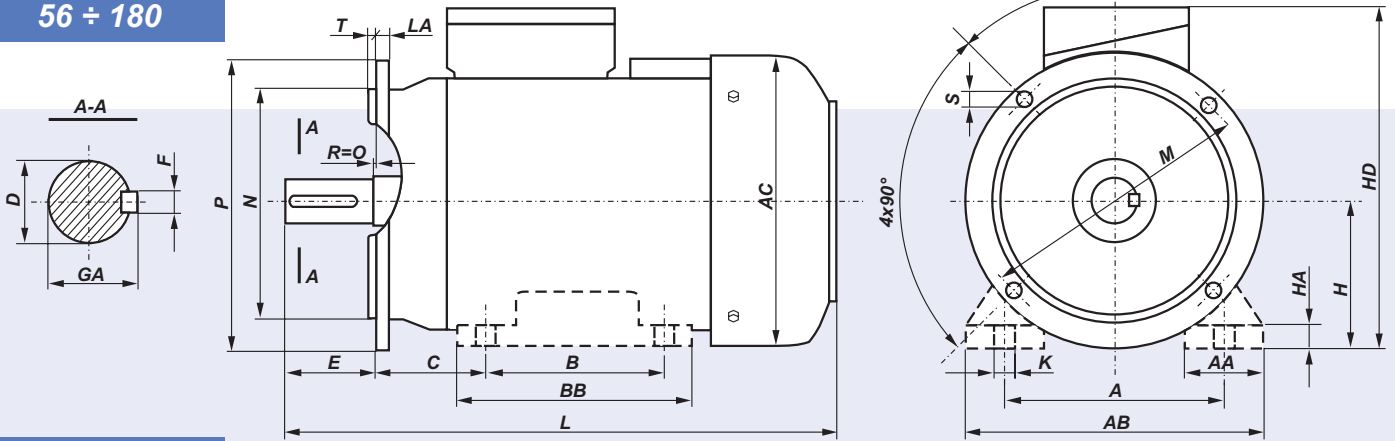

200 ÷ 315

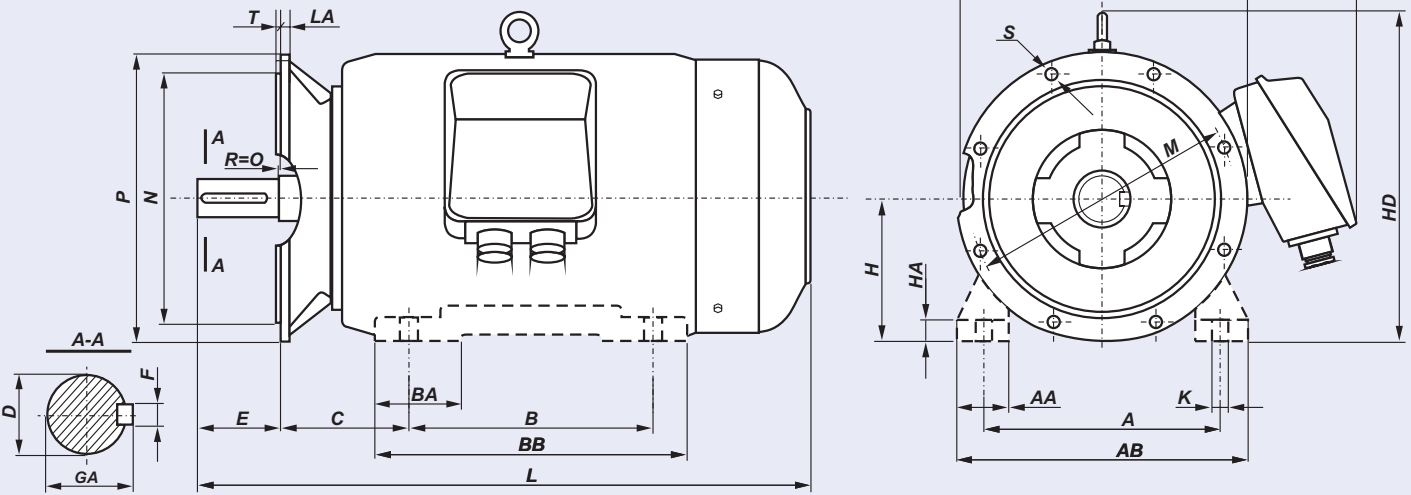

DIMENSION DRAWINGS

Type of motor	A	B	C	D	E	F	GA	H	HA	K	AA	AB	AC	AD/AD ¹	BA	BB	HD	L	LA	M	N	P	T	S	Φ	holes
STLg 56X-2+4C	90	71	36	9j6	20	3h9	10,2	56	7	5,8	30	110	117	-	-	92	154	204	8	100	80j6	120	3	7	4	
STLg 63X-2+6C	100	80	40	11j6	23	4h9	12,5	63	8,5	7	36	124	126	-	-	106	165	228	9	115	95j6	140	3	10	4	
SLh 71X-2+8C	112	90	40	14j6	30	5h9	16	71	8	7	45	142	141	-	-	116	182	263	9	130	110j6	160	3,5	10	4	
SLh 80X-2+8C	125	100	50	19j6	40	6h9	21,5	80	9	10	55	160	150	-	-	130	200	306	10	165	130j6	200	3,5	12	4	
SLh 80X-2+8D	125	100	50	19j6	40	6h9	21,5	80	9	10	55	160	150	-	-	130	200	318	10	165	130j6	200	3,5	12	4	
PSLh 90L-2+4	140	125	56	24j6	50	8h9	27	90	10	10	50	170	185	-	-	153	220	354	8	165	130j6	200	3,5	12	4	
PSLh 90L-6	140	125	56	24j6	50	8h9	27	90	10	10	50	170	185	-	-	153	220	330	8	165	130j6	200	3,5	12	4	
PSLg 100L-2+6	160	140	63	28j6	60	8h9	31	100	14	12	45	200	206	-	-	172	240	376	11	215	180j6	250	4	15	4	
PSLg 100L-4	160	140	63	28j6	60	8h9	31	100	14	12	45	200	206	-	-	172	240	411	11	215	180j6	250	4	15	4	
PSLg 112M-2+6	190	140	70	28j6	60	8h9	31	112	14	12	54	230	245	-	-	174	276	384	12	215	180j6	250	4	15	4	
PSLg 112M-2A,2B,4A	190	140	70	28j6	60	8h9	31	112	14	12	54	230	245	-	-	174	276	411	12	215	180j6	250	4	15	4	
PSLg 132S-2	216	140	89	38k6	80	10h9	41	132	16	12	56	278	274	-	-	182	310	531	12	265	230j6	300	4	15	4	
PSLg 132M-2+6,2A,4A	216	178	89	38k6	80	10h9	41	132	16	12	56	278	274	-	-	220	310	531	12	265	230j6	300	4	15	4	
SLg 160L2+8z	254	254	108	42k6	110	12h9	45	160	20	15	60	300	327	125/206	-	292	366	649	13	300	250j6	350	5	18	4	
PSLg 180L-2+4	279	279	121	48k6	110	14h9	51,5	180	26	15	70	350	360	-	-	320	408	756	13	300	250j6	350	5	19	4	
SLg 180M2z	279	241	121	48m6	110	14h9	51,5	180	24	15	75	330	365	125/220	-	320	400	675	13	300	250j6	350	5	18	4	
SLg 180L4+8z	279	279	121	48m6	110	14h9	51,5	180	24	15	75	330	365	125/220	-	320	400	675	13	300	250j6	350	5	18	4	
SLg 200 L2+8z	318	305	133	55m6	110	16h9	59	200	32	19	80	400	450	355/340	100	380	485	810	16,5	350	300j6	400	5	18	4	
SLg 225 M2z	356	311	149	55m6	110	16h9	59	225	34	19	85	445	505	375/360	110	380	535	855	18	400	350j6	450	5	18	8	
SLg 225 M4+8z	356	311	149	60m6	140	18h9	64	225	34	19	85	445	505	375/360	110	380	535	885	18	400	350j6	450	5	18	8	
SLg 250 M2z	406	349	168	60m6	140	18h9	64	250	36	24	90	495	540	415/405	120	420	590	980	19	500	450j6	550	5	18	8	
SLg 250 M4+8z	406	349	168	65m6	140	18h9	69	250	36	24	90	495	540	415/405	120	420	590	980	19	500	450j6	550	5	18	8	
SLg 280 M2z	457	419	190	65m6	140	18h9	69	280	40	24	100	560	620	450/440	165	520	660	1040	20	500	450j6	550	5	18	8	
SLg 280 M4+8z	457	419	190	75m6	140	20h9	79,5	280	40	24	100	560	620	450/440	165	520	660	1040	20	500	450j6	550	5	18	8	
SLg 315 M6+8z	508	457	216	80m6	170	22h9	85	315	46	28	105	610	620	450/440	190	560	695	1210	22	600	550js6	660	6	22	8	

¹ - AD - dimension for foot/flange mounted motors
AD1 - dimension for flange mounted motors

FOOT/FLANGE MOUNTED MOTORS - IM B34
FLANGE MOUNTED MOTORS - IM B14

56 ÷ 80

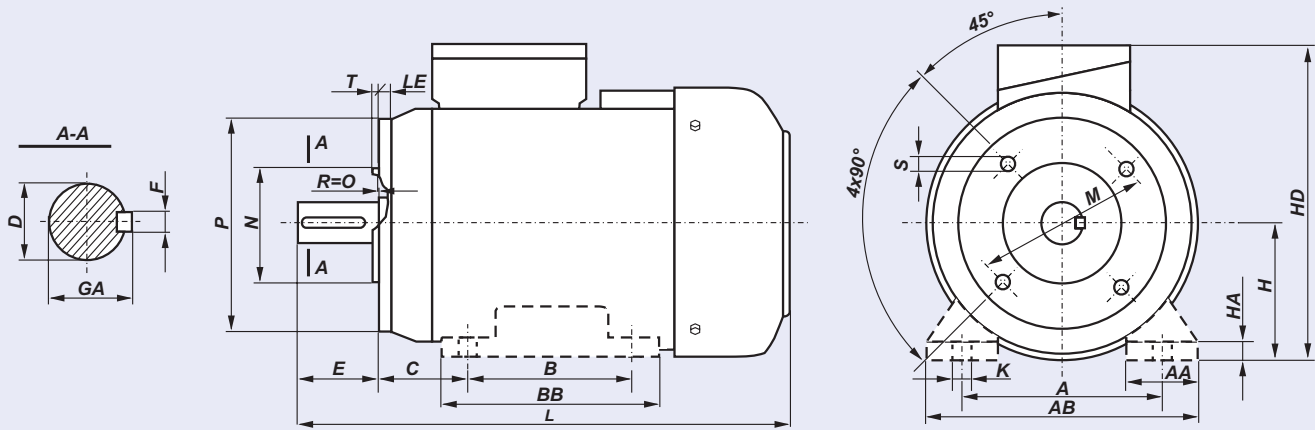

Type of motor	Flange	A	AA	B	C	D	E	F	GA	H	HA	K	M	N	P	S	LE	T	HD	L
STLg 56X-2÷4C1	B14/C1	90	30	71	36	9j6	20	3h9	10,2	56	7	8	85	70j6	105	M6	15	2,5	154	204
STLg 56X-2÷4C2	B14/C2	90	30	71	36	9j6	20	3h9	10,2	56	7	8	65	50j6	80	M5	12,5	2,5	154	204
STLg 63X-2÷6C1	B14/C1	100	36	80	40	11j6	23	4h9	12,5	63	8,5	10	100	80j6	120	M6	14	3	165	228
STLg 63X-2÷6C2	B14/C2	100	36	80	40	11j6	23	4h9	12,5	63	8,5	10	75	60j6	90	M5	9,5	2,5	165	228
SLh 71X-2÷8C1	B14/C1	112	45	90	45	14j6	30	5h9	16	71	8	10	115	95j6	140	M8	14	3	182	263
SLh 71X-2÷8C2	B14/C2	112	45	90	45	14j6	30	5h9	16	71	8	10	85	70j6	105	M6	12	2,5	182	263
SLh 80X-2÷8C1	B14/C1	125	55	100	50	19j6	40	6h9	21,5	80	9	10	130	110j6	160	M8	14	3,5	200	306
SLh 80X-2÷8C2	B14/C2	125	55	100	50	19j6	40	6h9	21,5	80	9	10	100	80j6	120	M6	12	3	200	306
SLh 80X-2÷8D1	B14/C1	125	55	100	50	19j6	40	6h9	21,5	80	9	10	130	110j6	160	M8	14	3,5	200	318
SLh 80X-2÷8D2	B14/C2	125	55	100	50	19j6	40	6h9	21,5	80	9	10	100	80j6	120	M6	12	3	200	318

DIMENSION DRAWINGS